

S T A R T E R M O T O R S

T Y P E	AZD	AZE	AZF	AZG	AZJ
---------	-----	-----	-----	-----	-----



Iskra

Iskra Avtoelektrika d.d.



MAIN TECHNICAL DATA

Type	AZD 21 .. - Nose AZD 26 .. - Noseless
Nominal voltage	12 V
Rated power	1.1 kW - 1.4 kW
Length-nose Length-noseless	< 200 mm < 201 mm
Weight-nose Weight-noseless	< 2.9 kg < 2.8 kg
Yoke diameter	70 mm
Stator	6-permanent magnets
Drive assembly	5 rollers
Solenoid	Pull-in current < 50A Hold-in current < 10A
Terminals	30 - M8 50 - M4 or M5, blade 6.4 x 0.8
Basic protection	Protection against ingress of dust, solid foreign objects and splashing water (IP56)
Operating temperature	- 30°C to + 110°C
Ambient temperature	- 40°C to + 130°C

STARTER MOTORS WITH REDUCTION GEAR AND PERMANENT MAGNETS

The advantages of these starters are compact dimensions, high specific power output and high efficiency resulting in excellent cold crank of the engine. Noseless version is available for specific design of some engines.

APPLICATIONS

Starter motors for petrol engines from 1.4 to 3.0-litre of capacity for passenger cars and light commercial vehicles.

FEATURES

- High specific power output and efficiency.
- Excellent cold crank capability.
- Reduced weight and dimensions in comparison to direct drive starter motors.
- Nose or noseless versions for specific applications.
- Pinion, flange, electrical terminals and sense of rotation are customized to the specific engines.
- Special versions are available on request.
- High reliability and long life operation.

DESIGN

- Pre-engaged system of starter motor.
- High quality ferrite permanent magnets.
- Epicyclical reduction gear for high torque output.
- Drive assembly with five rollers clutch.
- Pinion shift mechanism with solenoid and fork lever.
- Solenoid switch with pull-in and hold-in winding.
- High quality thermal resistant materials.
- Drive end brackets made of die cast aluminium.
- Drain holes on request.
- End-of-life Directive 2000/53/EC respected and also free of asbestos, beryllium and ammonia.

OPTIONS

- Dust protection of bushing in drive end bracket.

CROSS SECTION

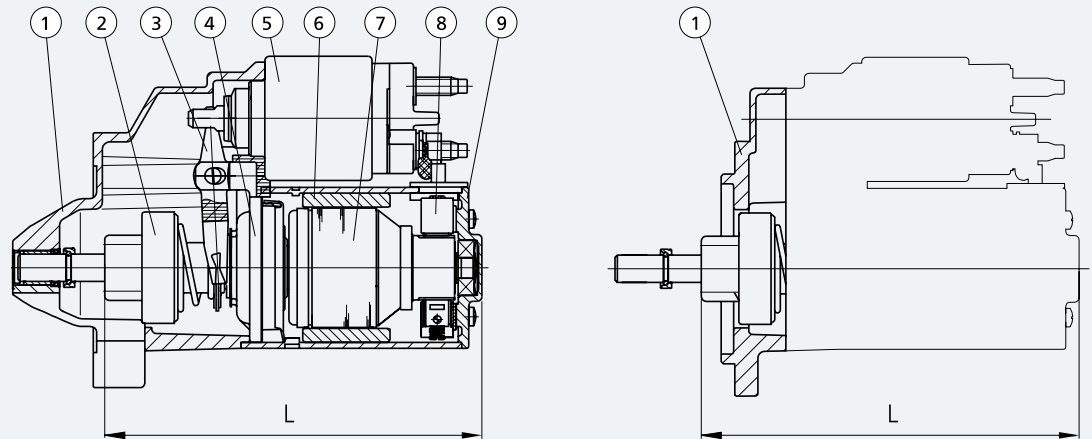

- 1. Drive end bracket • 2. Drive assembly • 3. Engaging lever • 4. Reduction gear • 5. Switch • 6. Stator
- 7. Armature • 8. Brush holder • 9. Commutator end bracket

CONNECTION DIAGRAM

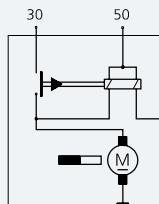

CHARACTERISTICS

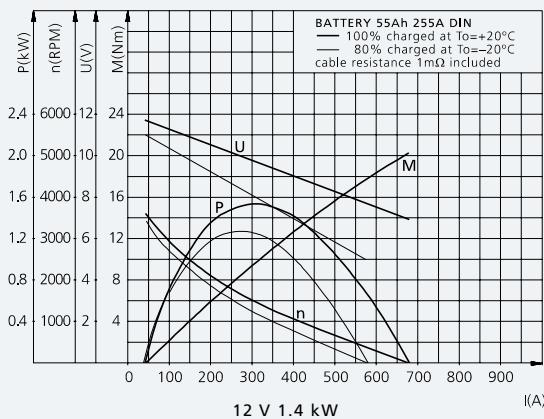
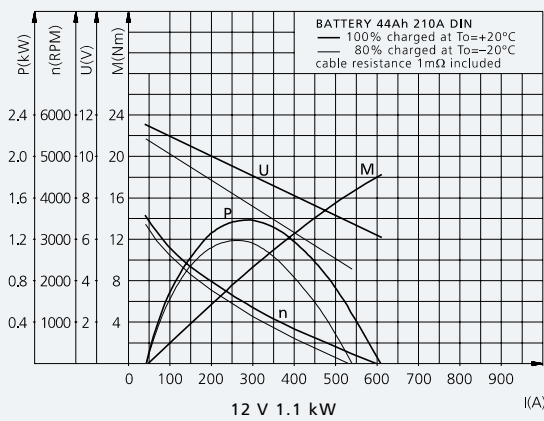

Iskra Avtoelektrika, d. d.

Polje 15, Slovenia,
5290 Šempeter pri Gorici
Tel.: +386 5 33 93 000,
Fax: +386 5 33 93 801
E-mail: info@iskra-ae.com
www.iskra-ae.com

BELARUS

IskRa o. o. o.
Ul. Dombrovskogo 69
230002 Grodno
Tel.: +375 152 487 484
Tel/Fax: +375 152 487 485
E-mail: iskra@mail.grodno.by

BOSNIA AND HERZEGOVINA

Iskra AE Komponente, d. o. o.
Nemanjina 35
78250 Laktaši
Tel.: +387 51 53 07 85
Fax: +387 51 53 53 15
E-mail: iskra-ae@inecco.net

BRAZIL

Iskra do Brasil Ltda.
Rua Testa n. 81 -
Jardim Sao Sebastiao
Jaguariuna - (SP)
CEP 13820-000
Tel.: +55 19 3837 2363
Fax: +55 19 3837 3185
E-mail: uros.kravos@iskra-ae.com
www.iskra-ae.com.br

CHINA

Iskra Suzhou Autoelectric Co., Ltd.
Wenzhou Industrial Zone Shuangfeng
Taicang, Jiangsu Province
Tel: +86 512 8160 6888
Fax: +86 512 8160 7799
E-mail: iskrasuzhou@iskra-ae.com
www.iskra-ae.com.cn

Changchun Fawer
Iskra Automotive Electrical Co., Ltd.
No. 2258 Pudong Road
Changchun Economic
Technology Development Zone
Changchun, Jilin Province
Tel.: +86 431 461 5016
Fax: +86 431 461 5017
E-mail: zhj_fa@faw.com.cn

FRANCE

Iskra Autoelectrique S.A.S.
ZA du Chapeau Rouge
56000 Vannes
Tel.: +33 2 97 45 59 90
Fax: +33 2 97 45 59 99
E-mail: iskra@iskra-sa.fr
www.iskra-ae.fr

GERMANY

Iskra Deutschland GmbH
Danziger Strasse 1
71691 Freiberg am Neckar
Tel.: +49 7141 702 69 0
Fax: +49 7141 702 69 33
E-mail: info@iskra-ae.de
www.iskra-ae.de

GREAT BRITAIN

Iskra UK Ltd.
Redlands
Ullswater Crescent, Coulsdon
Surrey CR5 2HT
Tel.: +44 208 668 7141
Fax: +44 208 668 3108
E-mail: sales@iskra-agency.co.uk
www.iskra-ae.co.uk

IRAN

Iskra Autoelectric Iran JVC
No.28, East Mirdamad Avenue
Tehran 15469-34311
Tel.: +98 21 2 226 237 1 - 4
Fax: +98 21 2 226 237 6
E-mail: info@iskra-iran.com

ITALY

Iskra Autel S. r. l.
Via G. Cantore, 2
34170 Gorizia
Tel.: +39 0481 536 800
Fax: +39 0481 536 810
E-mail: info@iskra-autel.it
www.iskra-autel.it

RUSSIA

Iskra Avtoelektrika
Representative Office
Storozhevaya str., 4,
building 1 office 123
111020 Moscow
Tel.: +7 095 726 93 94
Fax: +7 095 225 84 06
E-mail: info@iskra-ae.ru
www.iskra-ae.ru

Pramo Iskra o.o.o.
Zubcovskoe shosse 21
172387 Rzhev, Tverskaya obl.
Representative office in Moscow
Elektrozavodskaya str. 21
107023 Moscow
Tel. / Fax: +7 495 995 2512
E-mai: iskra@pramo.ru

SPAIN

Iskra Autoelectrique Spain S.A.
Calle Llobatona No. 6-D
08840 Viladecans
Tel.: +34 93 647 40 83
Fax: +34 93 647 40 84
E-mail: iskra@iskra-ae.es
www.iskra-ae.fr/esp/

USA

Iskra AE Inc.
4814 American Road
Rockford, IL 61109
Tel.: +1 800 474 1996
Tel.: +1 815 874 4022
Fax.: +1 815 874 4024
E-mail: iskra@iskraae.com
www.iskraae.com